

Head Office & Showroom:

Davy Avenue, Knowlhill
Milton Keynes MK5 8HJ
United Kingdom

Tel: +44 (0)1908 608888

Fax: +44 (0)1908 692399

www.morgana.co.uk

sales@morgana.co.uk



AutoCreaser Pro 33

High speed creaser with the NEW SmartScreen touch screen technology.



The AutoCreaser, made in the UK by Morgana, provides the complete solution to the problem of cracking that occurs when folding digitally printed output. It is equally effective in dealing with conventionally printed card, laminates or cross-grained stock.

Creasing versus Scoring.

Traditional rotary scoring machines use circular blades that are in constant motion as the stock passes through them. This creates a ploughing action that actually cuts through the top fibres of the paper or card in order to create a score. Inevitably this weakens the paper and encourages cracking. In contrast, the Morgana AutoCreaser Pro 33 employs a unique creasing rule and matrix as illustrated overleaf, that eliminates tearing and, therefore, cracking.

Key Product Features

- 7" SmartScreen touch screen
- Intuitive and easy to use
- Fully automatic
- Up to 16 creases per sheet
- Takes stock up to 0.4mm (approx 400 gsm)*
- Rule and matrix guaranteed for life
- 8500 sheets per hour
- Unlimited alpha numeric memory
- Adjustable crease depth & square
- Perforating as standard
- Crease without cracking

The new intuitive 7" SmartScreen controls all the main functions of the AutoCreaser Pro 33.



Using the screen is simplicity itself. Key in the sheet length (popular sizes are pre-set), touch the fold type for the finished product (letter, gate etc) and press the green button. The AutoCreaser Pro 33 will automatically calculate where the creases need to be and set them accordingly.

Any minor changes to the crease position can be made by touching an arrow in the relevant direction.

The productivity of the AutoCreaser Pro 33 has been improved with a massive 50% increase in speed with no loss of accuracy. Now running at 8,500 A4 sheets per hour, and an astonishing 11,000 A5 sph, this is our most productive creaser to date.



The AutoCreaser Pro 33 has the new Morgana PosiFeed feeding system. The drum stops as the vacuum pulls the sheet down before the drum begins to feed. This significant change will enable the feeder to be piled higher and feed the most difficult of stocks.

All settings and adjustments are made using the new SmartScreen and as only symbols are used, operation couldn't be simpler. An alpha-numeric memory allows an unlimited number of jobs to be stored and named as you choose. This makes job recall much easier as you can use your own job name and numbers for storage.

Any changes to the suction drum, feed method, crease position and engineering settings are all made through the SmartScreen which has been developed and designed to make the AutoCreaser Pro 33 the easiest machine to operate whilst offering levels of sophistication never before seen at this price point.

Perforation comes as standard on the AutoCreaser Pro range with a wide variety of wheels available to suit all applications.

AutoCreaser Pro 33

High speed creaser with the NEW SmartScreen touch screen technology.



technical specifications

Maximum sheet size	700mm x 330mm
Minimum sheet size	210mm x 140mm
Maximum paper thickness	0.4mm (approx 400 gsm)* including laminated material
Minimum paper thickness	0.11mm (approx 80gsm)*
Maximum number of creases per sheet	16
Maximum number programmed applications	Unlimited alpha numeric
Minimum repeat crease distance	1mm (depending on paper weight)
Minimum crease distance from lead edge	2.5mm
Minimum crease distance from tail edge	35mm
Speed per hour	8500 sph (A4), 11,000 sph (A5)
Dimensions	L 1450mm x W 522mm x H 1224mm
Weight	121kgs
Power requirement	240v 50/60hz
Options	Narrow creasing blade, Narrow sheet guide

Note: the production speed varies according to material size and the number of creases on the sheet

Creasing rule and matrix. The AutoCreaser Pro 33 uses an identical mechanism to that on the more expensive AutoCreaser Pro 50, DigiFold Pro and DocuMaster Pro and is guaranteed for life. With thousands of these mechanisms installed throughout the world our creasing technology is unparalleled in both performance and longevity.

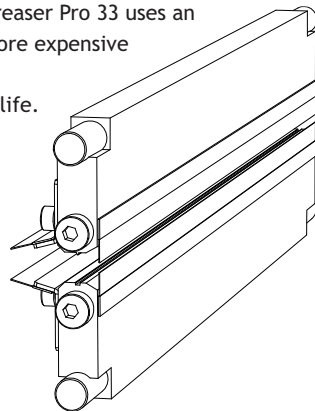

*Disclaimer

As part of our continued product improvement plan, specifications and information published here are subject to change without notice.

All specifications are dependent on application, type of stock, temperature, RH and print engine used.

Specifications quoted were measured on uncoated and unprinted stock.

E & OE.